

Techna STRAIGHTENERS (WIRE & STRIP)

ERS - Heavy Duty Straightener with Quick Release

Used in applications where the process material is both large and hard, thus the unit has large solid rolls with bearings as inserts and heavy duty roll spindles. With manual quick release.

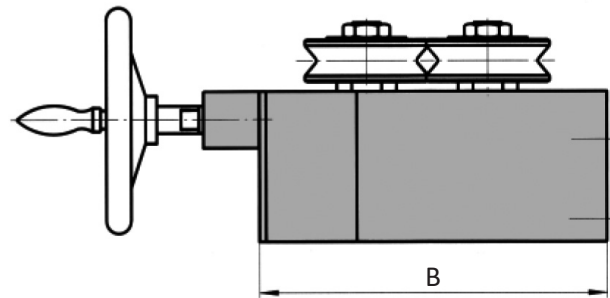
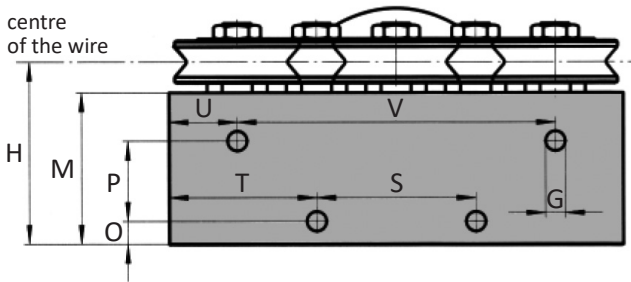
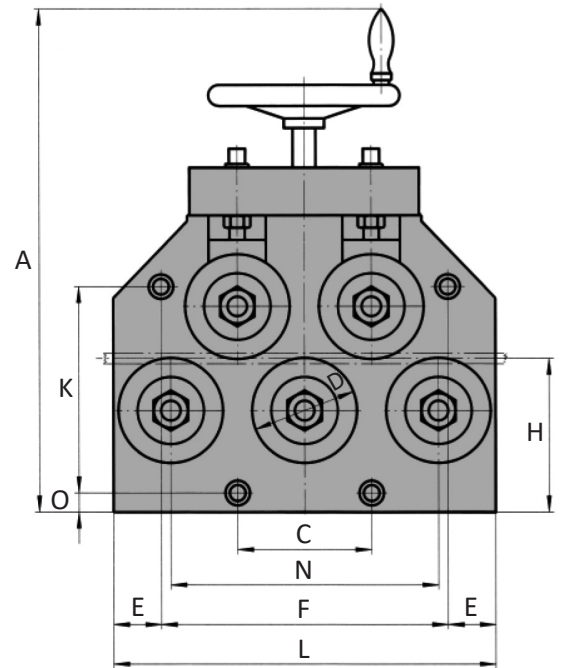
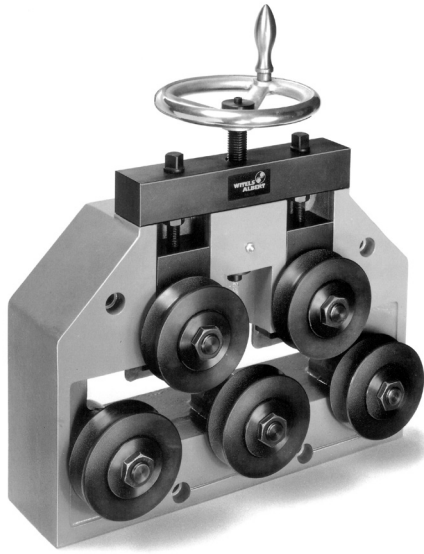

ERS Series	Wire Diameter Ranges (mm) ϕ			
	5 - 15	10 - 20	15 - 25	20 - 30
Order Ref.	ERS5-15.0	ERS5-20.0	ERS5-25.0	ERS5-30.0
A	445	530	570	615
B	242	310	350	380
C	260	140	180	220
D	80	110	125	150
E	19.5	50	70	25
F	260	300	360	550
G	17	17	17	17
H	120	160	160	180
K	130	215	250	210
L	299	400	500	600
M	98	132.5	132.5	130
N	200	280	360	440
O	20	20	20	25
P	50	70	70	70
S	160	140	180	440
T	69.5	130	160	80
U	99.5	60	70	190
V	100	280	360	220
Kg	38	67	92	165
Rolls	WR80	WR110	WR1251	WR1500